

<Variant Name>
MAIN

4Z5LV		Rev
http://4z5lv.net		A
Title AFEDRI-NET		
Size B	Document Number AFEDRI03	Rev A
Date: Wednesday, December 07, 2011	Sheet 1 of 8	

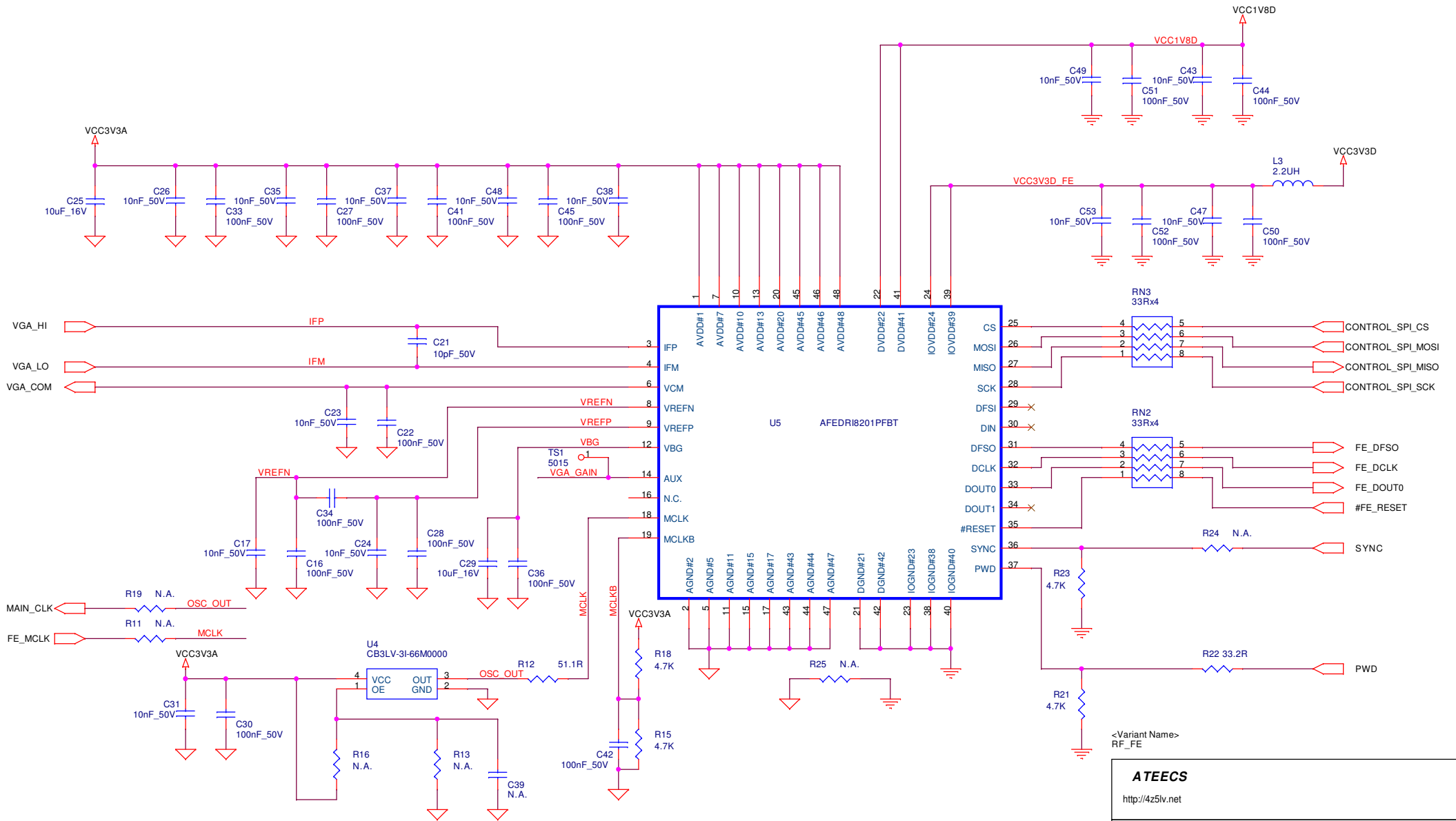

<Variant Name>
RF_FE

ATECS		
http://4z5lv.net		
Title		
AFEDRI-NET		
Size	Document Number	Rev
B	AFEDRI03	A
Date:	Wednesday, December 07, 2011	Sheet 2 of 8

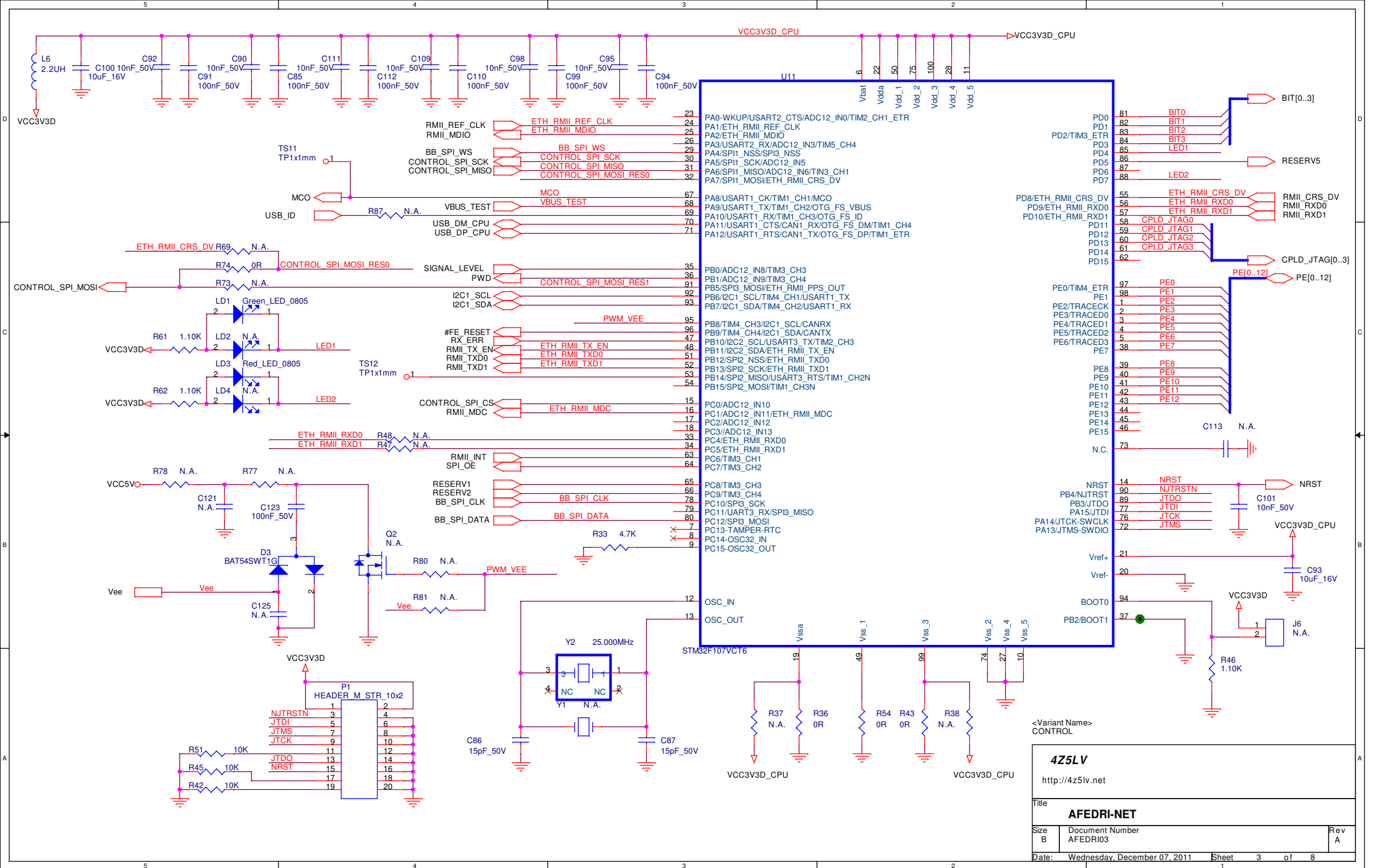

<Variant Name>
CONTROL

4Z5LV		
http://4z5lv.net		
Title AFEDRI-NET		
Size B	Document Number AFEDRI03	Rev A
Date: Wednesday, December 07, 2011	Sheet 3 of 8	

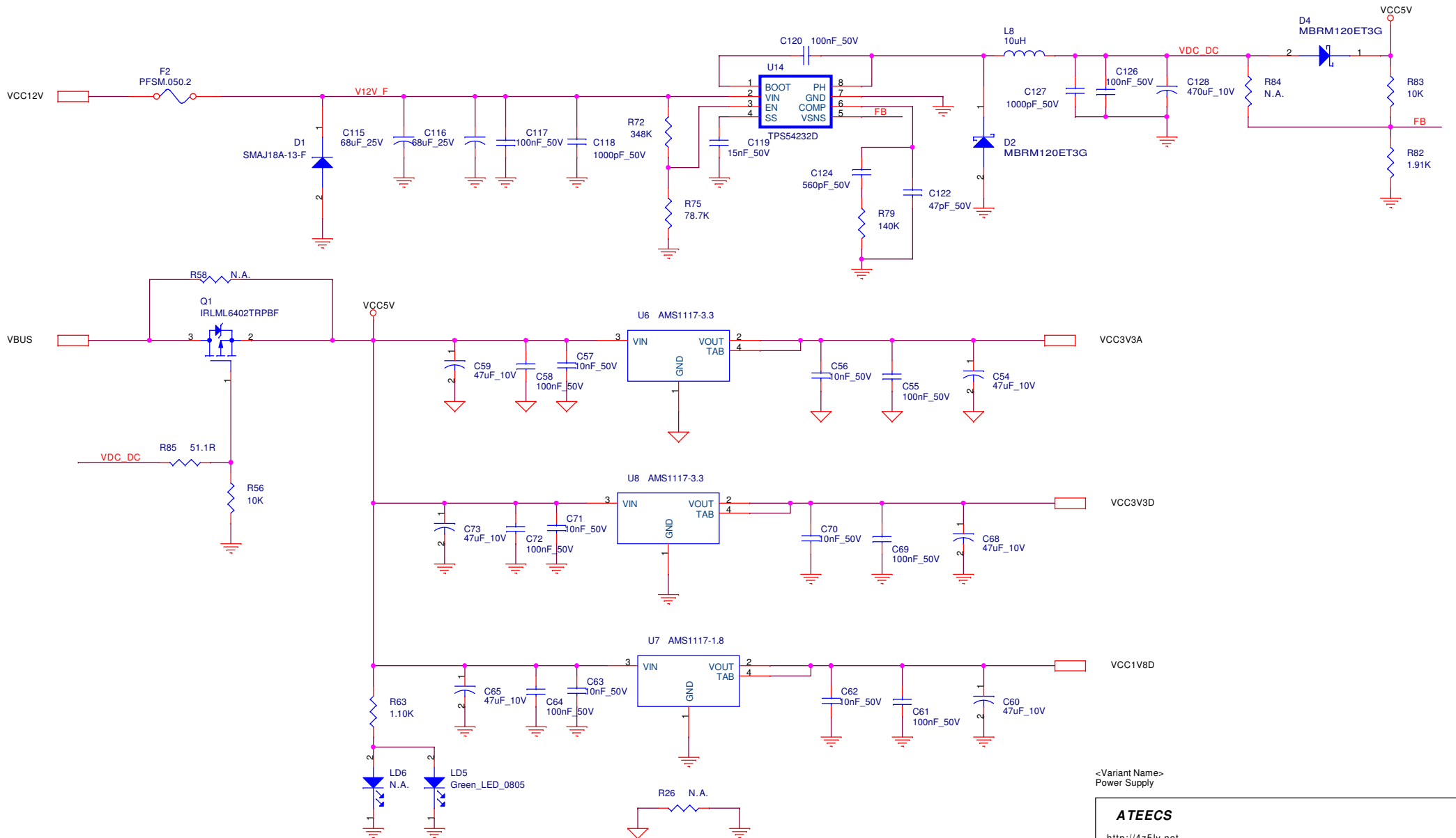

<Variant Name>
Power Supply

ATECS
http://4z5lv.net

Title
AFEDRI-NET/ Power Supply

Size B	Document Number AFEDRI03	Rev A
-----------	-----------------------------	----------

Date: Wednesday, December 07, 2011 Sheet 4 of 8

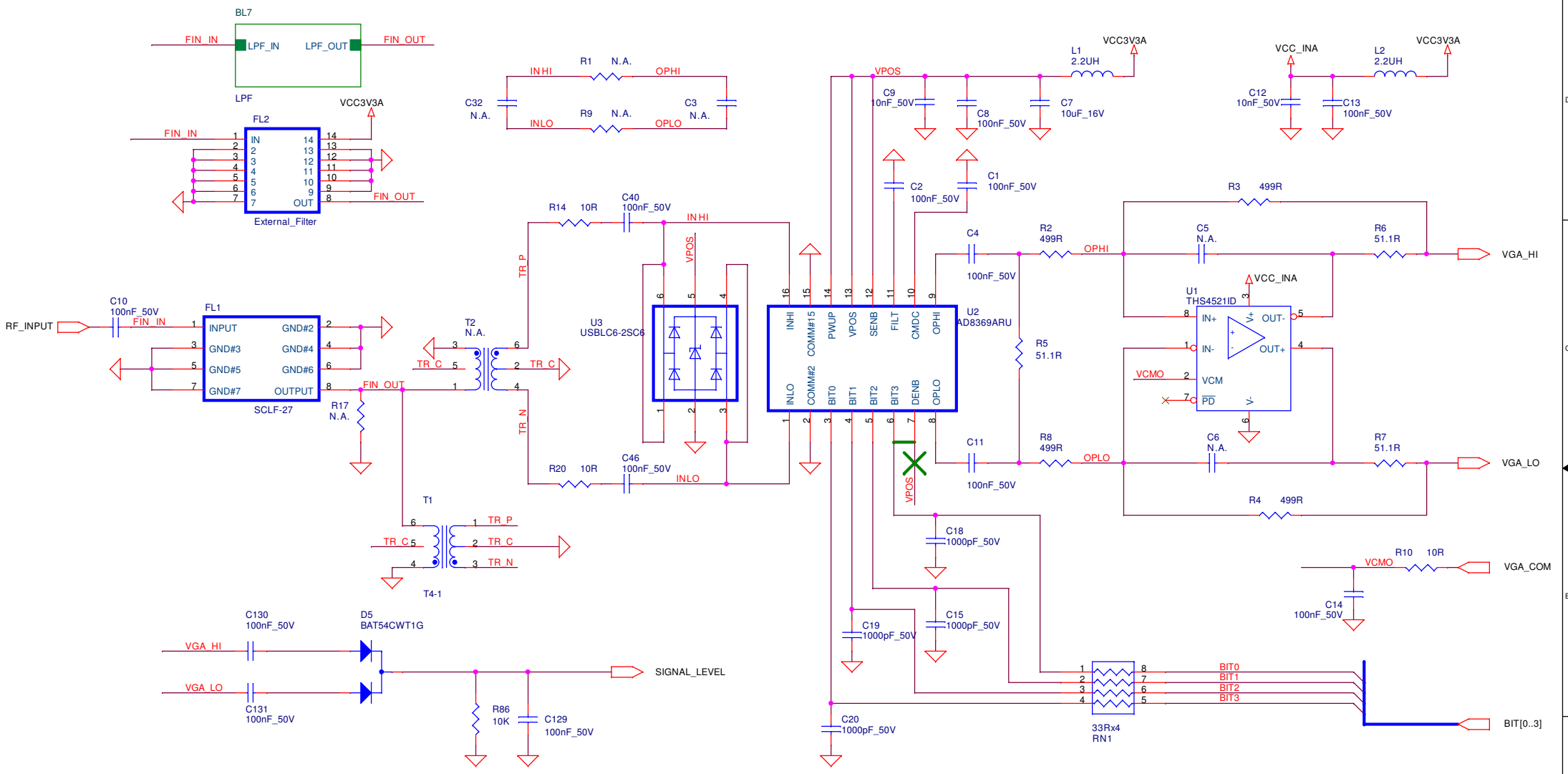

<Variant Name>
RF_SWITCH

ATECS		
http://4z5lv.net		
Title		
AFEDRI-NET		
Size	Document Number	Rev
B	AFEDRI03	A
Date:	Thursday, December 29, 2011	Sheet 5 of 8

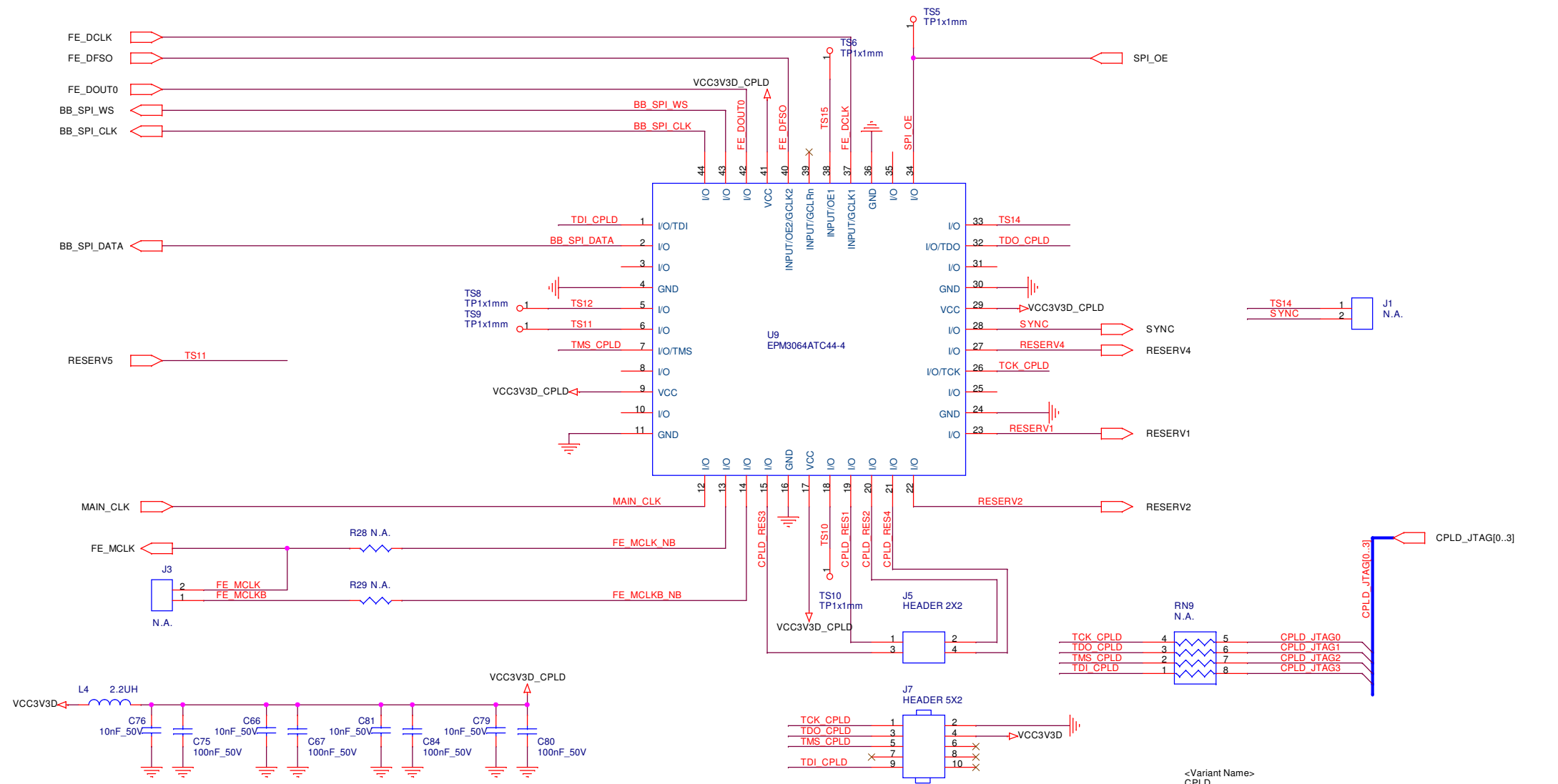

<Variant Name>
CPLD

4Z5LV		
http://4z5lv.net		
Title AFEDRI-NET/CPLD		
Size B	Document Number AFEDRI03	Rev A
Date: Wednesday, December 07, 2011	Sheet 6 of 8	

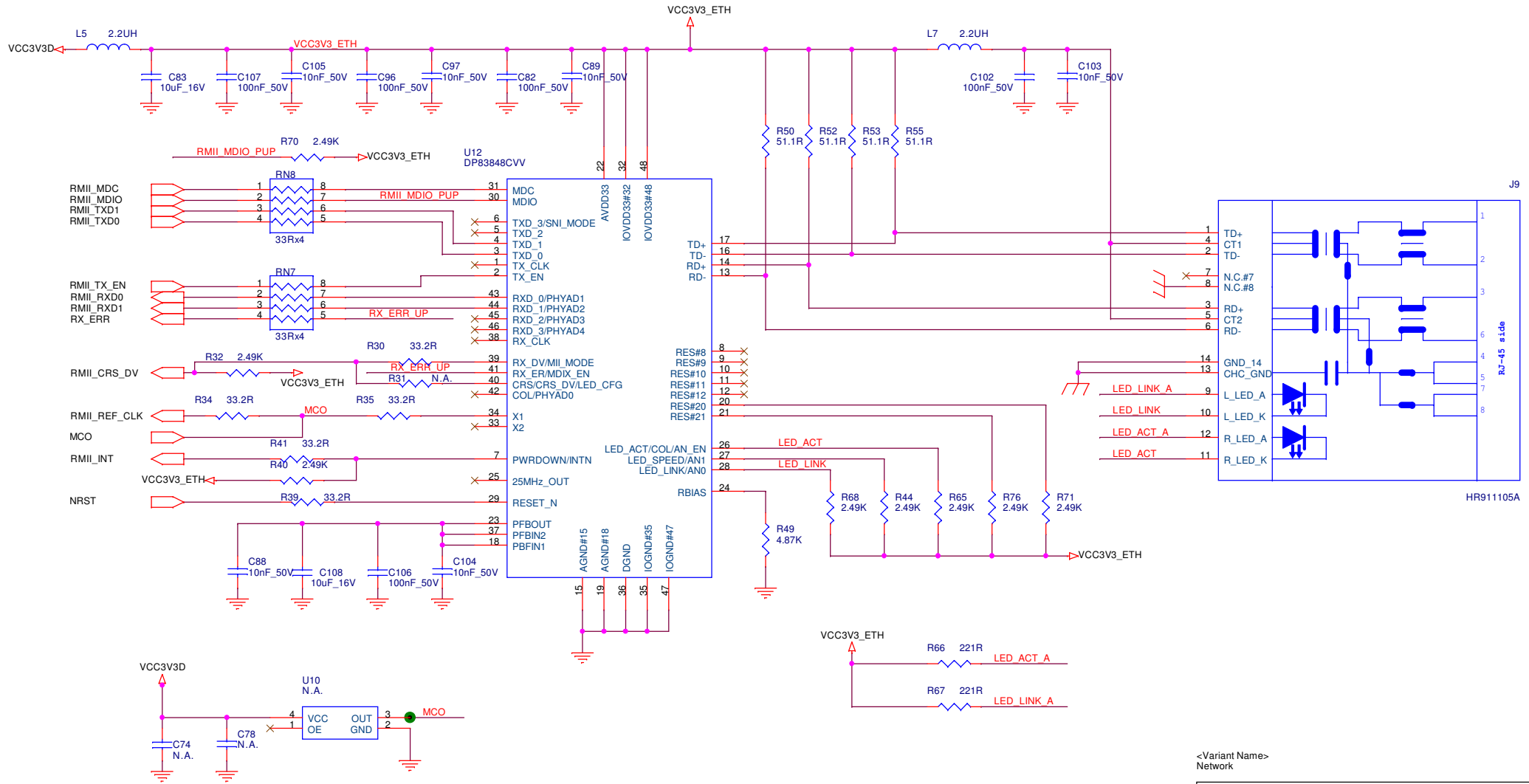

<Variant Name>
Network

ATECS		
http://4z5lv.net		
Title		
AFEDRI - Network		
Size	Document Number	Rev
B	AFEDRI03	A
Date:	Wednesday, December 07, 2011	Sheet 7 of 8

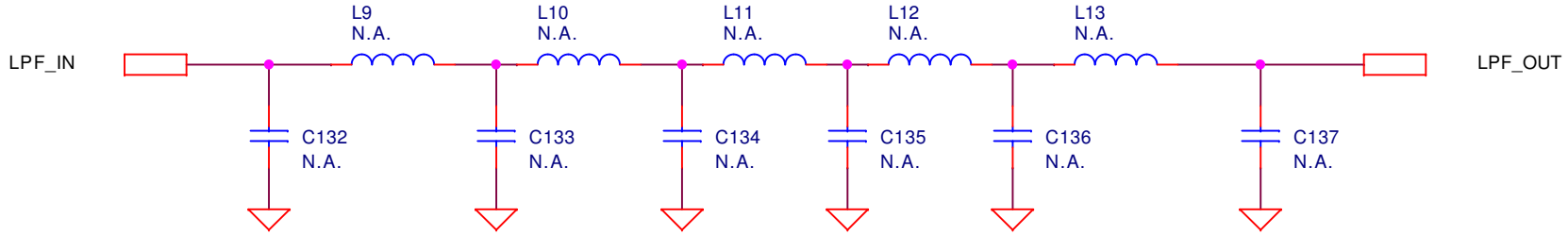

<Variant Name>
LPF

4Z5LV

<http://4z5lv.net>

Title

AFEDRI-NET/LPF

Size
A

Document Number
AFEDRI01

Rev
A

Date: Wednesday, December 07, 2011 Sheet 8 of 8